

Pressure Control Valves

"M" Plus™ Pressure Control Valves

Rexroth
Bosch Group

M-2 Lever Operated

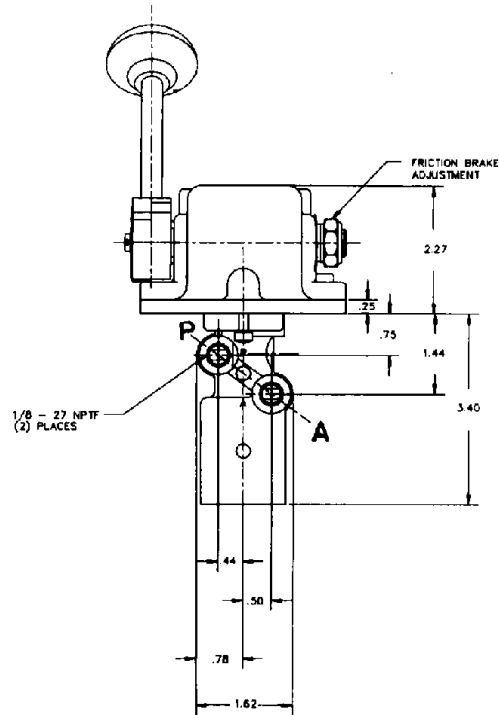
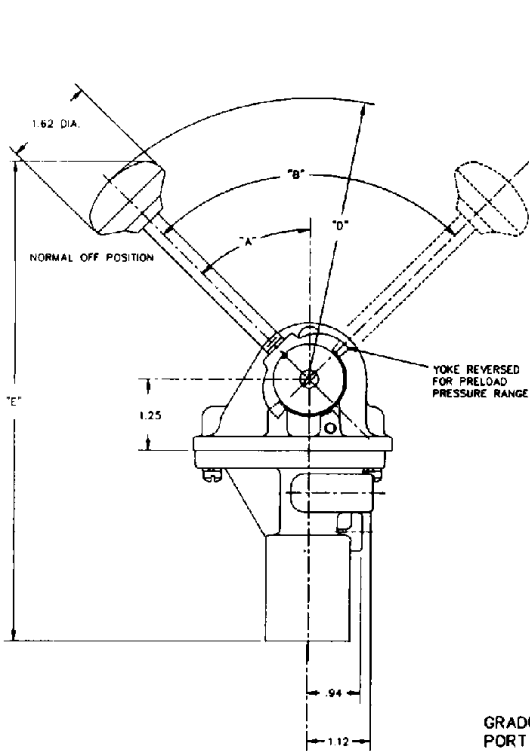

GRADUATING VALVE PORT LEGEND

P = SUPPLY
A = DELIVERY
MAX. INLET = 150 PSI

NOTES:

ON VALVE PC. NO. P26773-1 CAM HOUSING AND HUB IS CHROME PLATED, AND HANDLE IS STAINLESS STEEL.

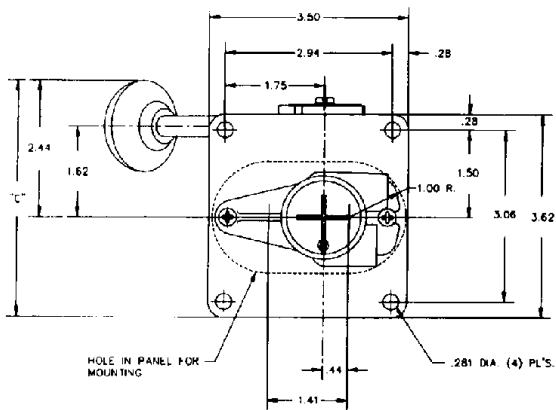

PC. NO.	RATING	"A"	"B"	"C"	"D"	"E"	REMARKS
P26714-2	0-100 PSI						Spring Returned Handle
P26714-1	0-60 PSI	45°	90°	4.25	5.09	8.68	
P26773-1	0-60 PSI	45°	90°				Friction Retained Handle, See Notes
P26715-11	0-60 PSI	30°	75°	4.34	5.09	8.68	Friction Retained Handle
P26715-2	0-100 PSI	45°	90°				
P26715-1	0-60 PSI						